

Diode Theory

(note: This is 90% correct. There are subtleties that this discussion brushes over.)

A diode allows current to flow in only one direction. A diode consists of a semiconductor pn junction:

In Silicon, the number of free electrons is a constant:

$$np = n_i^2 \approx (1.5 \cdot 10^{10})^2$$

In p-type silicon, you dope the silicon with Boron, with a typical doping of 10^{14} atoms per cc

$$p_p \approx 10^{14}$$

$$n_p = \left(\frac{n_i^2}{p} \right) = 2.25 \cdot 10^6$$

In n-type silicon, the doping is Phosphorus, resulting in

$$n_n \approx 10^{14}$$

$$p_n = 2.25 \cdot 10^6$$

At the pn junction, some electrons and holes are created through thermal electrons. This is a small number, however, so assume it's zero. If electrons and holes are not created, current can only flow by electrons and holes flowing towards the pn junction (where they combine and disappear).

Assume the current is flowing from the p-side to the n-side (the left figure below.) In this case, you are using majority carriers, so there are approximately 10^{14} charge carriers.

Now, assume the current is flowing from the n-side to the p-side. In this case, you are using minority carriers, resulting in only $2.25 \cdot 10^6$ charge carriers. If the diode has a resistance of 1Ω when using majority carriers (current p to n), it has a resistance of $44M\Omega$ when using minority carriers (!).

A diode only allows current to flow from p to n

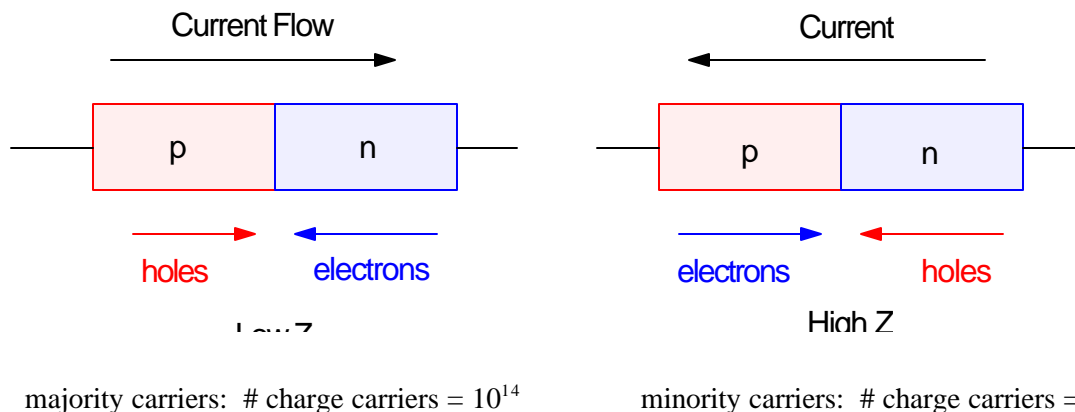

Transistor Theory

Assume you have a npn transistor. Let the doping at the base (p) be 10^{14} and the doping at the emitter be 10^{16} (n).

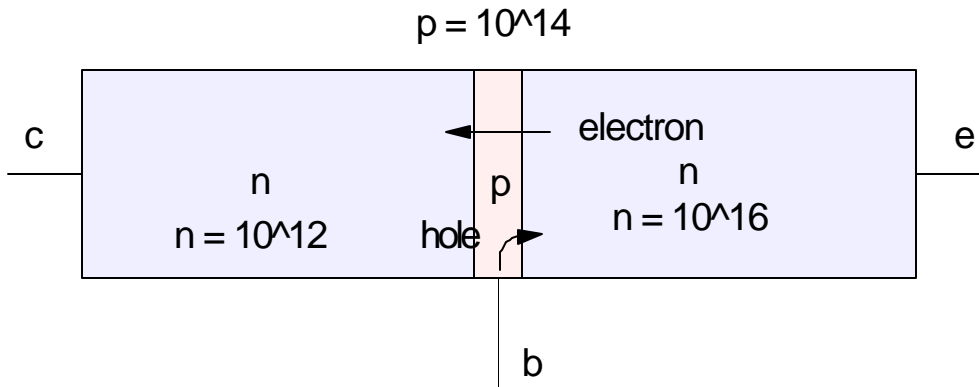

If current is flowing from base to emitter, holes are flowing from the p to n region. Due to the doping, for every hole, there are 100 electrons flowing the other way.

If you make the base very thin, most of the electrons will shoot past the base and wind up in the collector. There, they are majority carriers, so they flow freely to the collector terminal.

As a result, this transistor looks like it has a current gain:

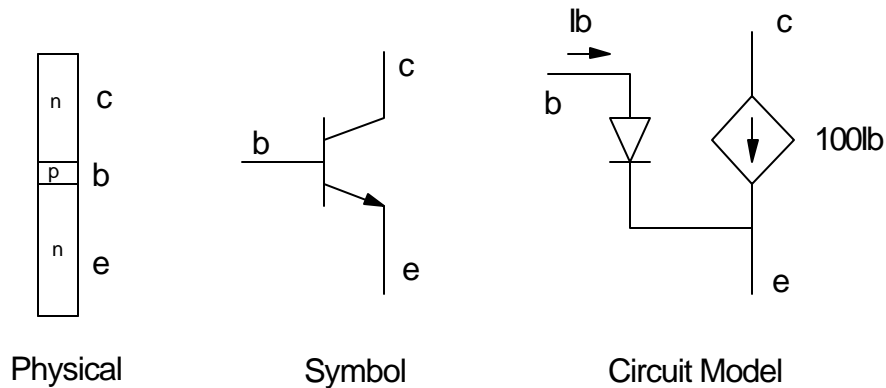

A transistor is just a piece of silicon. Likewise it can't actually create current. Some other circuit needs to be added to try to push the current through the transistor. The transistor simply acts as a current limiter: the current which is allowed to pass from the collector to the emitter is

$$I_{ce} \leq \beta I_{be}$$

Using a Transistor as a Switch

Transistors can be used as a switch or a current amplifier. For example, suppose you want to design a circuit which allows a PIC processor to drive an LED array. This LED array has the following properties:

$$V_f @ 80mA = 10.2V \quad (\text{six red LEDs are placed in series, giving } 6 \times 1.7V = 10.2V)$$

$$48,000 \text{ mcd} @ 80mA$$

Assume that the PIC is only capable of driving 10mA at 5V.

Step 1. Find a transistor which can withstand 80mA. From Digikey, a ZTX1051A transistor has the following properties.

- $300 < h_{FE} < 1000$ *meaning you can count on a gain of at least 300*
- $\max I_C (\text{Sat}) = 4000mA$ *meaning this can take 4000mA. 80mA is a breeze*
- $V_{CE} (\text{Sat}) = 0.21V$ *a rough estimate of V_{CE} at saturation*
- $V_{CEO} = 40V$ *meaning this transistor can take +40V when turned off*
- Price: \$0.85 ea. *a little more expensive than a 2n222*

Step 2: Find a power supply bigger than 10.2V. Arbitrarily assume a +24 supply.

Step 3: Find R_C to limit the current to 80mA

$$\bullet \quad R_C = \left(\frac{24V - 10.2V - 0.2V}{80mA} \right) = 170\Omega$$

Step 4: Find R_B to saturate the transistor. At the lowest gain, to put you just at the point of saturation,

$$I_B = \frac{I_{CE}}{\beta} = \frac{80mA}{300} = 267\mu A$$

$$R_B = \frac{5V - 0.7V}{267\mu A} = 16k\Omega$$

Pick R *smaller* than this to assure you saturate this stage.

$$\text{Let } R_B = 10k.$$

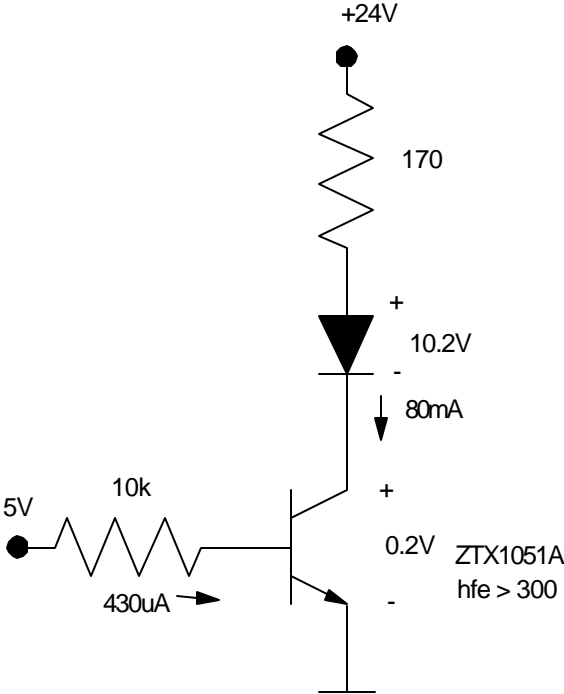

Example 2) Design a circuit which

- uses a single output from the PIC processor, and
- allows a PIC processor to drive this motor in the clockwise direction at either 0% speed (0V) or 100% speed (+5V). Assume the motor draws 470mA at +5V.

Step 1: Pick a transistor. I'll stick with a ZTX1051A because I like this transistor.

Step 2: Add the motor to the collector. You don't need a current limiting resistor since the motor's armature resistance and back EMF limit the current to 470mA @ 5V.

Step 3: Add R_B to saturate the transistor. Worst case, when the gain is minimum (300) and you're just at the point of saturation:

- $I_B = \frac{I_{CE}}{\beta} = \frac{470mA}{300} = 1.57mA$
- $R_B = \frac{5V-0.7V}{1.57mA} = 2.74k\Omega$

Step 4: Just to make sure that you saturate the transistor, make R_b smaller than this. Let $R_b = 2k$.

note: The inductance in the motor stores energy in a magnetic field. When the current is turned off (the transistor turns off) the energy in the field has to go somewhere. To save the transistor, place a diode across the motor to allow the collapsing field to drive current through the diode - saving the transistor.

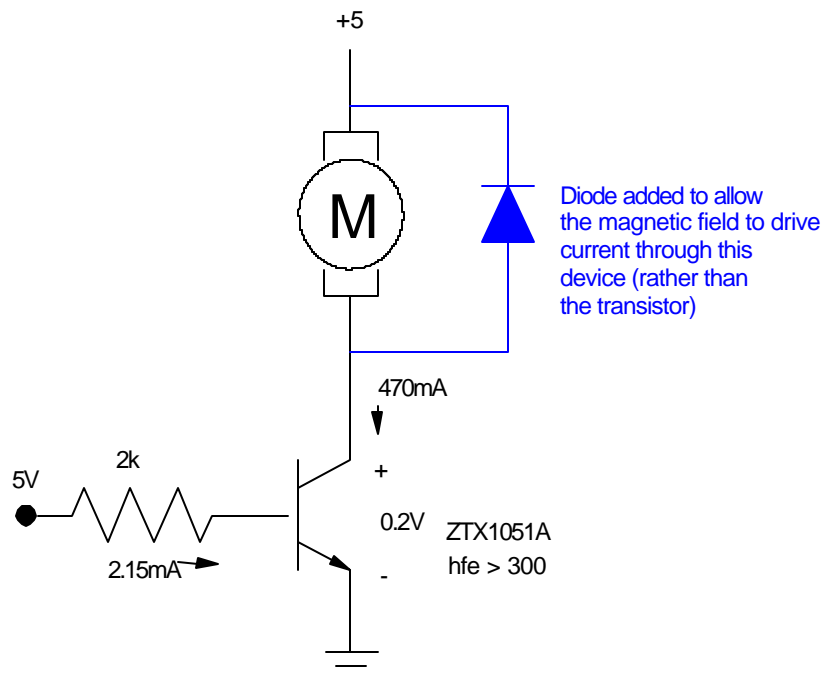

Example 3) Design a circuit to drive 1 Amp across an LED with $V_f = 7V$. Design the circuit to draw less than 1mA from the PIC @ 5V.

Solution) You need a gain of 1000 to turn 1mA to 1A. To get this much gain, use a Darlington pair. This is two transistors connected so that the gain is $\beta(\beta + 2)$

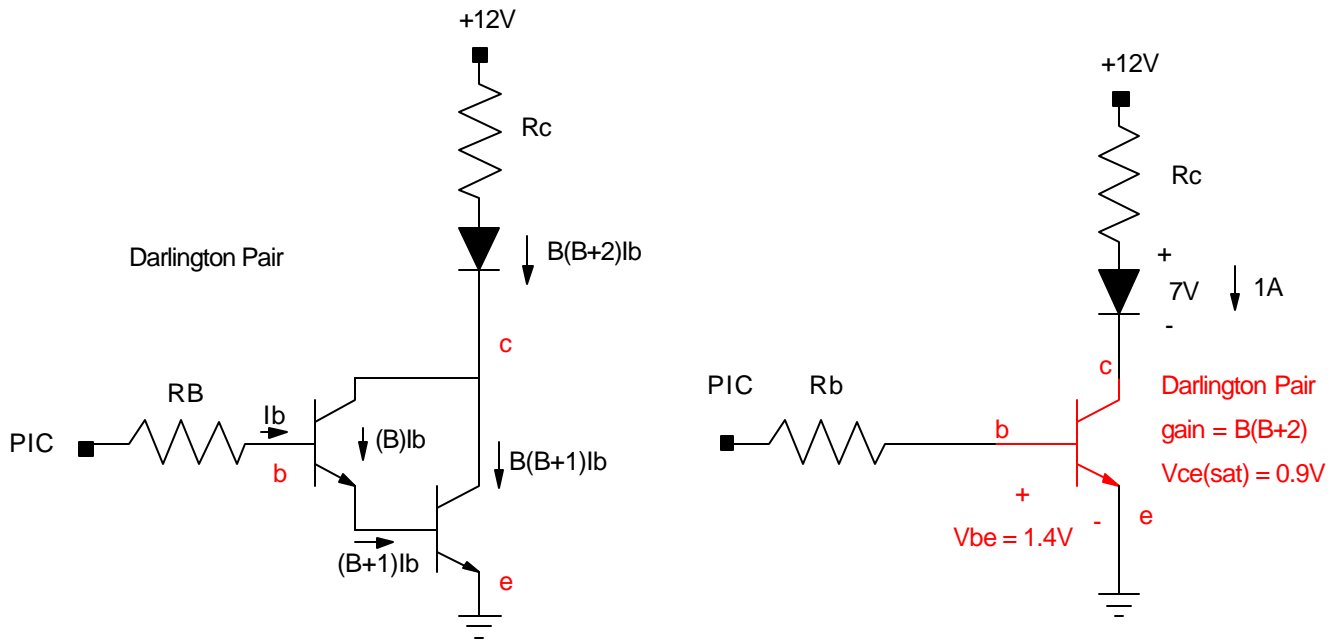

Assume you're using a 2n222 with a gain of 100. With a Darlington pair, the gain is 10,200.

Finding R_c :

$$R_c = \left(\frac{12V - 7V - 0.9V}{1A} \right) = 4.1\Omega$$

Finding R_b :

$$\beta I_b > I_c$$

$$(10200) \left(\frac{5V - 1.4V}{R_b} \right) > 1A$$

$$37,200\Omega > R_b$$

Let $R_b = 20k$

$$I_b = \left(\frac{5V - 1.4V}{20,000\Omega} \right) = 0.18mA$$

Note that a Darlington pair has

- A higher current gain than a single transistor, but
- $V_{ce} = 0.9V$ (0.7V for V_{be} + 0.2V for V_{ce}). The transistors absorb more energy.
- $V_{be} = 1.4V$ (0.7V + 0.7V). It takes more voltage to turn on the pair.

Example 4) Design a circuit which can drive the motor forward and in reverse using transistors:

You can use the same circuit as before, only add another NPN and two more PNP transistors. The equations work out the same for each transistor:

NPN:

- OFF: put the input to 0V. This assures that 0A flow through the diode.
- ON: make $R_B = 2k$ to saturate this transistor when 470mA flow through it.

$$I_B > \frac{470mA}{\beta} = 1.57mA$$

$$R_B < \frac{5V-0.7V}{1.57mA} = 2.74k\Omega$$

Let $R_B = 2k$.

PNP: (since I picked a transistor with the same gain (β))

- OFF: put the input to +5V. This assures there is no potential across the base diode and no current flows.
- ON: Make $R_B = 2k$ to saturate this transistor when 470mA flows through it.

$$I_B > \frac{470mA}{\beta} = 1.57mA$$

$$R_B < \frac{5V-0.7V}{1.57mA} = 2.74k$$

Let $R_B = 2k$.

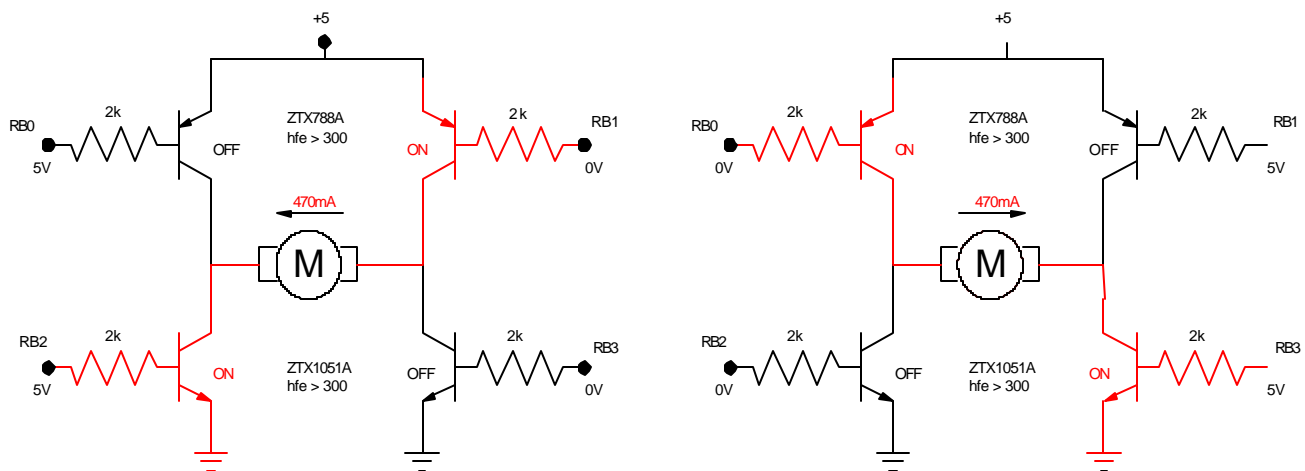

This results in

- BRAKE (OFF): PORTB = bxxxx 1111.
- COAST (OFF): PORTB = bxxxx 1100.
- CW (left figure): PORTB = bxxxx 1010.
- CCW (right figure): PORTB = bxxxx 0101.

